

## Instruction manual *For safety cabinet*



*(Picture : Model 90 minutes ; Bench not included)*

### Model 3031ARD

# CONTENT

---

<b>1.</b>	Description / Use	Page 2
<b>2.</b>	Technical features	Page 2
<b>3.</b>	Installation and commissioning	Page 2
<b>4.</b>	Internal equipments	Page 7
<b>5.</b>	Storage	Page 7
<b>6.</b>	Ventilation	Page 7
<b>7.</b>	Safety controls	Page 9
<b>8.</b>	Spare parts	Page 9
<b>9.</b>	Recycling	Page 9
<b>10.</b>	Warranty	Page 9
<b>11.</b>	Control sheet for the user	Page 11

## 1. DESCRIPTION / USE

The 30-minute fire resistant safety cabinets are compliant to the standard EN 14470-1. They allow you to safely store your flammable products and delay spreading of potential fire in the cabinet, while waiting for rescue unit arrival.

## 2. TECHNICAL FEATURES

### Compliance :

- Compliance with the standard EN 14470-1 – 30 minutes (04/2004) et EN 1363/1 (06/2000)
- Compliance with the standard FM 6050 (Factory Mutual International)
- Standardized pictograms, compliant with the standards ISO 3864 and ISO 7010, with the directive 92/58/CEE, with the standard EN 14470-1 (04/200) and FM specifications.
- Compliance with the articles R. 5132-66 and R. 5132-68 of the Public Health Code

### Technical features :

- Fire-proof 30 minutes according to the ISO 834 fire heating curve
- Insulation panels offering a high resistance against the chemicals
- Grey safety cabinet RAL 7035 + yellow outline RAL1023
- Standardized pictograms provided
- 3-point locking-system and no-sparking lock
- Ventilation openings, with a connecting sleeve diameter 100 mm for an eventual connection
- Ventilation ducts with a thermo-fuse
- Thermo-expanding door seals, allowing to insulate the content of the safety cabinet in case of a fire
- Self-closing doors with the possibility to keep the doors open
- If the temperature rises to 43°C, the doors are closed automatically
- External dimensions : H 635 x W 605 x D 630 mm
- Storage capacity : 30 liters
- Weight : 60 KG

## 3. INSTALLATION AND COMMISSIONING

### Installation

The safety cabinet has to be installed on a flat surface that can bear its weight with the products inside.

Ensure that the safety cabinet is correctly wedged, as for the cabinet not to topple, and for the automatic locking system to work correctly. The eventual blocking has to be done by the user.

In order to wedge the cabinet, you need to use the levelling feet that are situated under the cabinet. Remove the containment sump and remove the pellets to access the holes. The feet can be adjusted with a flat-head screwdriver.

Once adjusted, put back the pellets on the holes.

The correct leveling of the cabinet must cart off any distortion of the frame, allow the doors to be strictly parallel compared to the frame, and take away any rubbing of the doors on the cabinet's frame.

The installation location must guarantee :

- That it is not exposed to any heat source
- That it is protected against moisture and that the ambient temperature of the location is neither less than 5°C, nor more than 40°C

### **Transport and handling**

The safety cabinet that you received has been protected and transported in optimal conditions, as to be protected from any damage.

It has to be lifted only by suitable equipment (suction cup, strap...). It has to be carried in a vertical position, and it must not be lying. It is imperative not to tilt the cabinet when it is carried. Indeed it can cause damages that can alter the right functioning of the cabinet.

On the other hand, if it has to be moved, the cabinet has to be placed on a pallet and strapped, as to avoid any fall.

### **Commissioning**

After having unwrapped the cabinet, ensure that you also received a set of two keys.

Your safety cabinet has to be installed, used and maintained as to guarantee the users protection.

#### *Swing doors*

The swinging doors can be open by pulling the handle. The automatic closing system allows the doors to be closed systematically after every use (if the blocking doors system is not activated).

#### *Door closing mechanism*

The door closing mechanism is adjusted in the warehouse, in usual conditions. In case of an important evolution of the temperature, its behaviour can evolve.

If the cabinet has been delivered during summer or winter, an adaptation period to the ambient temperature might be required. This period can last up to 12 hours.

#### *Door blocking system*

The door blocking system allows maintaining the doors open, during an undetermined period. It allows safe manipulation of the chemicals.

If the ambient temperature rises over 50°C, the opened door gets unlocked and will automatically close.

It is mandatory for safety reasons, not to impede the proper closure of the doors with an object and to maintain the doors closed if the cabinet is not used.

Waste recovery system

## Sound and visual alarm Signalbox

### Front view

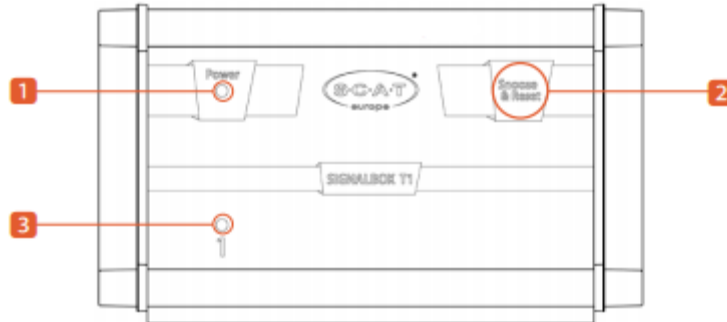

1/ Power – On/Off switch with green LED

2/ Snooze and reset button

3/ Status channel 1 with green LED

### Back view

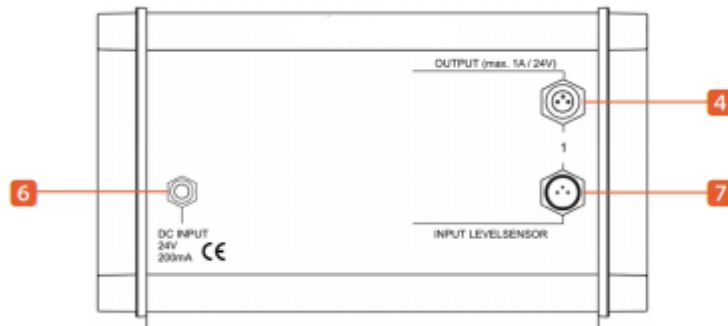

4/ Output – Potential-free switch, channel 1

6/ DC input – 24V electrical power supply

7/ Input level sensor, channel 1

### Technical features

- Dimensions : H 105 x W 180 x D 55 mm
- Weight : ca. 620g
- Power supply : 24V
- Switching power : 24V / 2A
- Power consumption : Max. 4W
- Operating temperature : +5°C to +40°C
- Display : LEDs

## Level control sensor

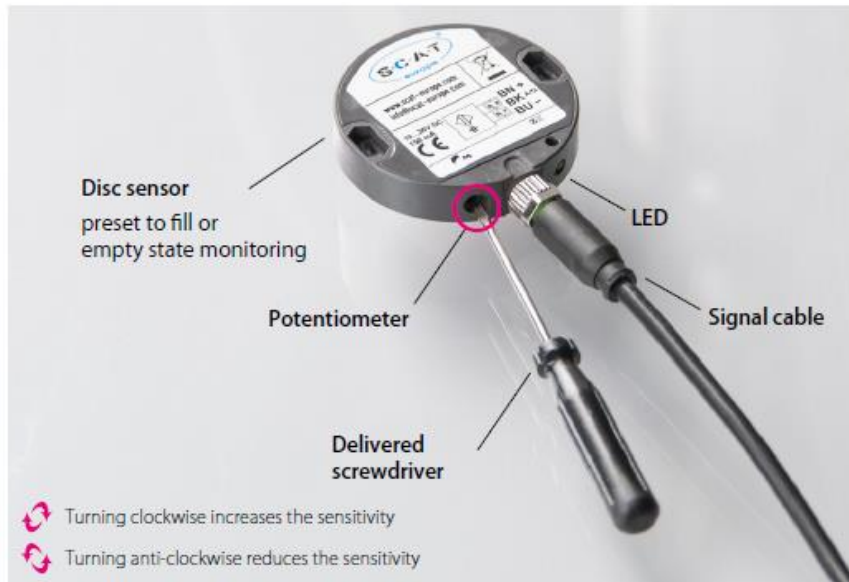

## Safety advice

- Always put the devices in a safe and dry place, and protect them from moisture.
- Do not drop the devices. Fix cables safely and do not pull them by force.
- **Important notice** : Before operation, please ensure correct function of the level sensor (Disc sensor or SafetyWasteCap). The floater on your SafetyWasteCap might be stuck or unmovable by sticky or viscous fluids. Check floater and level control mechanism constantly for dirt or contaminants. The floater must be freely movable. Clean and purge the floater if necessary with a suitable solvent or clean water.

## Commissioning

### 1. Power supply :



Connect the Signalbox to your power supply, using the delivered ac/dc adapter 6. Now the power-LED lights up in green.

### 2. Connect signal cable :





Connect the level sensor with the desired channel of the Signalbox 7 by using the signal cable. Now the Status-LED 3 lights up in green.

## LED index :

### Power LED

	Off	Device off
	Green	Device on

### Status LEDs

	Off	No sensor connected
	Green	Sensor connected
	fast red flashing	Max. filling level reached
	slow red flashing	Max. filling level reached, Snooze-Mode is activated

Use the delivered mounting material to fasten the disc sensor at the required height of the container. For fill state monitoring, we recommend a position at about 90 % of the maximum container capacity, for empty state monitoring, the disc sensor should be mounted at a height of approx. 10 % of the container capacity.

The disc sensor can be adjusted to different container materials, respectively wall thickness, using the integrated potentiometer at the bottom of the small side of the disc sensor.

For adjusting the sensitivity please use the delivered screwdriver. Turning the potentiometer clockwise increases the sensitivity, while turning it anti-clockwise reduces the sensitivity.

Please use the delivered screwdriver only, otherwise the disc sensor could be damaged.

For calibration of the disc sensor and its sensitivity please slightly fill the container with a convenient fluid. Adapt the disc sensor to the container wall, at the height of the fluid level and verify that the complete sensor disc surface is covered by the fluid level.

During alert, (LED at the disc sensor flashes up), please turn the potentiometer anti-clockwise until the alert ends (LED at the disc sensor off). At next please turn the potentiometer clockwise and leave it close, next to a position where the disc sensor alerts.

Put the sensor into a position above the fluid level to test the correct function. If the sensor also alerts here, please readjust.

## Level alert

If a container hits the max. filling level, the Signalbox gives an acoustic warning signal and the corresponding LED 3 flashes red in a fast interval. Please proceed as follows :

### **Set the alarm in Snooze-Mode**

Press the Snooze & Reset button 2. Now the acoustic warning signal becomes silent for 60 seconds and the LED of the corresponding channel 3 flashes red in a slow interval. The container must be emptied now. If the Signalbox will not be reseted within the next 60 seconds, the acoustic warning signal will start again with LED 3 flashing red in fast intervals regarding the filling level state. If another container hits the max. filling level during this time (affects only Signalbox T5) the Signalbox will also alert acoustically and fastly flashing, even if a different channel is resting in Snooze-Mode. This container has to be emptied now also.

### **Empty the container**

Dispose the container contents. Use the mandatory way of disposal!

*Warning:* Always wear adequate and suitable protective clothing when working with hazardous chemicals!

*Attention:* Do not dispose chemical waste through your canalization or domestic waste! Follow your local laws and directives when disposing fluid waste or other chemicals! Please ask your official safety inspector and your environmental authorities for more information and applicable law!

#### **Reset**

Hold the Snooze & Reset button 2 for 3 seconds to reset all channels. Now the Status LEDs 3 change to green light. For those containers that still hit max. fill level, the alert will recur automatically. Press and hold of the Snooze & Reset button is approved by a key tone.

### **4. INTERNAL EQUIPMENTS**

The cabinet is provided with 1 retention tank. The waste recovery system is equipped with a 12L white canister, one sound and visual alarm, one disc level sensor, one funnel, one hose and two adapters.

The retention tank has to be positioned at the bottom of the cabinet. If you want to use it as a storage area, you must place in a perforated cover plate (P/N C148) that is suitable for your containment sump. The latter has a retention capacity of 20 liters.

*Be aware that placing a perforated cover plate decreases the total retention capacity of your containment sump. The volume of your containment sump is approximately reduced by 3 liters.*

### **5. STORAGE**

Your safety cabinet is exclusively destined to store chemicals in laboratories, industries, schools... in closed containers. It must not store high concentrated corrosive products.

We remind you that the storage of corrosives can alter the quality of your safety equipment. On the other hand, we remind you that damages due to a bad use of the equipment and in particular to corrosion won't be covered by our warranty.

It is highly recommended to connect your safety cabinet to a ventilation system.

*Warning ! The HPL plank situated at the upper part of the cabinet must not be used as a storage location, neither be removed.*

### **6. VENTILATION**

First of all, you need to remove the red covers, which are positioned on the ventilation openings of the cabinet.

As to evacuate the vapors, you need to connect the connecting sleeve, which possesses the red arrow indicated "OUT". The air inlet possesses a green arrow indicated "IN".

We highly recommend connecting your safety cabinet to a ventilation system, as to evacuate the eventual vapors contained in it. The air renewal has to be at least 10 times the volume of the cabinet, per hour. Moreover, ensure that the ventilation runs 24h/7.

**In compliance with the standard EN 14470-1** and as to avoid any confinement of the vapors, ventilation is required to assure an air renewal. Every user has to contact his chemicals supplier or the safety officer of his company, before storing any chemicals. See our ventilation and filtration boxes range technical datasheet.



## Connection to a ventilation system

The air inlet and outlet are situated in the back of the cabinet. See the below outline.

<b>Model</b> <b>3031ARD</b>	<b>ECOSAFE</b> www.ecosafesa.com
Scale 1 : 15 Measure unit : mm Date : 06/03/2019	Chemin des Champs Courbes 15 – Zone Industrielle de Vallaire Est CH-1024 Ecublens Tél : +41 (0)21 694 11 04 <small>ECOSAFE reserves the right to          discontinue or change specifications at          any time without notice.</small>

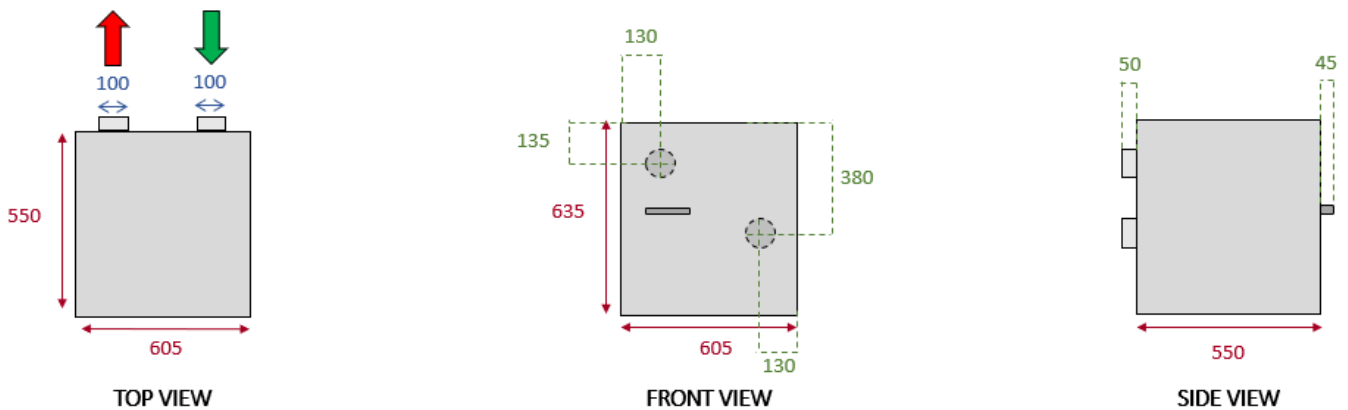

## How to choose a ventilation or a filtration box ?

**Ventilation boxes** are connected to the safety cabinet with a connecting kit (including a connecting sleeve, 2 hose clamps and 1 meter of flexible sheath) ; the fan included in the box extracts the toxic vapors contained in the cabinet, and reject it to the outside of the building thanks to the roof or wall extraction.

If you cannot reject the vapors to the outside, you need a filtration box.

**Filtration boxes** are equipped with an activated carbon filter, which purifies the toxic vapors in the box, and rejects it in the room in a healthy fashion. Filtration boxes are delivered with the activated carbon filter that you need to renew once a year.

## Running without any mechanic ventilation

It is possible for your safety cabinet to run without mechanical ventilation. However, your cabinet has to be placed in a location that provides its own ventilation system (at least 5 times the volume of the location, per hour).

The cabinet itself and a radius of 2,5 meters directly around is a dangerous area subject to explosions.

On the other hand, if the ventilation system of your cabinet is not running, you have to indicate it, by putting an etiquette on the cabinet, saying "Safety cabinet not connected to the mechanic ventilation" (etiquette is not provided).

## 7. SAFETY CONTROLS

Your safety cabinet is a safety equipment. As to guarantee its perfect efficiency, you have to check the equipment regularly.

**Daily safety controls :**

- Check if the products (liquids, powders...) have flowed in the containment sumps. If it has, they have to be emptied and cleaned promptly, with suitable equipment (absorbent mat...).
- Check that the cabinet and its internal equipments are not corroded.
- Check that the cabinet does not have any mechanical damages.
- Check the proper closing of the doors.
- Check the proper working of the locking system.

**Monthly safety controls :**

- Check the proper working of the doors (opening and closing)
- Check the working of your ventilation system thanks to, for example, a piece of paper  
(*Only if your cabinet is connected to a mechanical ventilation system*)

**8. SPARE PARTS****Elements :**

- Thermo-expanding door seals : *Contact us*
- Door handle : *Contact us*
- Locking system + set of keys : *Contact us*
- Standardized pictogram : P/N **PICTOEN**
- System to maintain the doors open : *Contact us*
- Door closer mechanism : *Contact us*
- Containment sump : P/N **B148**
- Perforated cover plate : P/N **C148**

**9. RECYCLING**

The safety cabinet can be entirely dismantled. Various elements such as the steel can be recycled. Ensure to respect the national and local waste disposal terms. Those elements should not be mixed with household waste.

**10. WARRANTY**

Your equipment holds a 12 months warranty against every manufacturing defect (limited to ordinary conditions of use, from the date indicated on the delivery note).

Our warranty can be applied only in case of manufacturing defects or hidden fault. The warranty covers only the replacement of the faulty goods or pieces indicated by our quality or technical department, as they are the only one able to determine the condition. Repair of the equipment must be performed in our warehouse.

The spare parts are under 3 months warranty upon their settlement.

The warranty cannot be applied in the following cases :

The equipment has not been stored, used or maintained in accordance with the standards by the user

In case of a damage of the equipment by the user or a third party

The equipment had a modification or a repair by the user or a third party, without any prior written authorization by ECOSAFE

In case of a bad use of the equipment

In case of a normal attrition of the equipment

In case of a bad installation of the equipment

In case of damage caused by the corrosion

The activation of the warranty won't extend the term. Our warranty stops if the customer has not notified us in a 7 days term after seeing the fault ; date that the customer has to prove.

## 11. CONTROL SHEET FOR THE USER

	YES	NO
The opening and the closing of the doors are working correctly		
The locking system of the doors works correctly		
The automatic closing of the doors works correctly		
The doors blocking system works correctly		
The mechanic ventilation system is running correctly (if applicable)		
The ventilation system is not obstructed		
The air inlet and outlet are clean		
The standardized pictogram on the door is in good condition and visible		
The door hinges are lubricated		
The locking system is lubricated		
The shelves and the containment sump are clean		
The door seals are in good condition		
<u>Remarks :</u>		
<p><b>Date :</b></p> <p><b>By :</b></p> <p><b>Signature</b></p>		